



www.genesislamp.com
info@genesislamp.com
Toll Free: 800-685-5267

GENESIS LAMP

375 North St. Clair St.
Painesville, OH 44077

RCM-D L-893(L) Runway Closure Marker

• FAA Certified • Buy American Qualified

ETL Certified to FAA AC 150/5345-55 latest revision,
Engineering Brief 67, with FAA AC 150/5370-2 and
NTSB Safety Recommendation A-03-05

**More LED's. Less Intense.
Better defined lighted "X"
for pilots.**



**Compact transporting.
Compact storage.**



Applications:

- The Runway Closure Marker is an effective method to warn pilots of closed runways and taxiways

Options:

- Optional Rear Hitch for tandem towing
- Optional Cover
- Optional Extended service kit
- Optional Pintle hitch
- Optional Oil Drain Kit for easier oil changes
- Optional 24hr Battery Backup: Lighted "X" automatically switches over to battery power when generator power is lost or turned off manually. Fuel saving and emergency backup

Features:

- Easily set up by one person in less than 5 minutes
- External power compatible, Lighted X can be powered from an external power source from 120 to 277v 50/60 Hz.
- 50,000hr built in LED lamps. Never change a bulb
- Reliable diesel engine with shore power output (20amp 120V and 30amp 240Volt)
- 140+ hour runtime between fueling
- Wind tested to 95mph
- 2 year/2000 hour engine warranty
- Visible 10-25 miles from runway under VFR
- Photocell dimming for night operation
- DOT compliant trailer with lights, Highway towable, with a standard 2" hitch
- Compact transporting and storage design



www.genesislamp.com
info@genesislamp.com
Toll Free: 800-685-5267

GENESIS LAMP

375 North St. Clair St.
Painesville, OH 44077

RCM-D L-893(L) Runway Closure Marker

Set Up Procedure (5 minutes):



1. Level as necessary using 3 leveling jacks



2. Extend the 4 light assembly arms



3. Tilt the light to the upright position



4. Start the generator and activate the lights

Light Assembly Specifications

- Arm length 14 feet when operating
- Hinged to generator housing, swings upright for use, swings to horizontal position when stowed
- Assembly arms fold to a 5'x5' square for transport and storage
- Arms constructed of 4"x4" extruded aluminum, with yellow epoxy powder-coat paint.
- Twenty LED lamps mounted in front, plus 4 monitor lamps in rear, 24 total
- LED lamp, 20 degree beam width, rated life 50,000 hour typical
- Lamps flash 2.5 seconds on, 2.5 seconds off
- Solid-state flasher, no mechanical contacts
- Photocell automatically reduces intensity at night
- Maximum Power: 630 watts, 643VA at 120VAC

Engine Specifications

- Engine: 3-cylinder Diesel, 12.7 hp, liquid-cooled, 4-stroke, 1800 RPM, electric start
- Engine Warranty: 2 years/2000 hour
- Glow plugs and elapsed hour meter
- Low oil/high temperature auto-shutdown
- Generator: Marathon Electric, 6.0 kW, 120/240VAC 60Hz, 4-pole, brushless
- Fuel tank capacity 57 gal., consumption 0.4 gph 140 hour + runtime

Specifications:

- Width:67" Length:117" Height:69" 1405 lbs (dry)
- Total wet weight 1804 lbs
- Fully Crated Width:72" Length:96" Height:79 2050 lbs

Warranty

- LED Lamps warranty: 4 Years
- Engine/Generator Warranty: 2 years/2000 hour
- Trailer and all other components 2 years
- Please see owners manual for specific warranty coverage specifications

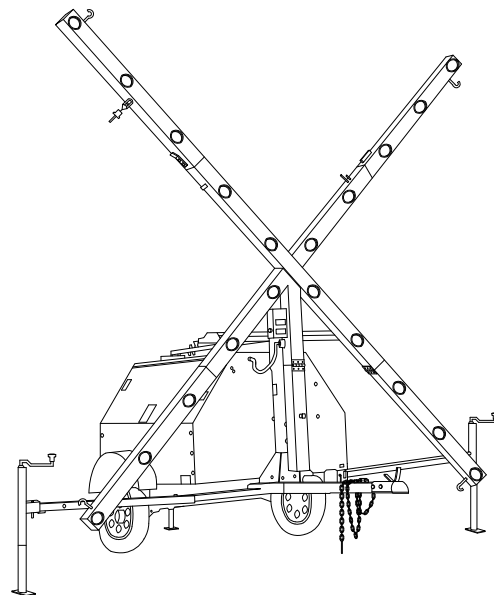



www.genesislamp.com
 info@genesislamp.com
 Toll Free: 800-685-5267

GENESIS LAMP

375 North St. Clair St.
 Painesville, OH 44077

RCM-Extended Service Kit



Maintenance

Basic Maintenance Schedule

See the original equipment manufacturer's operating manual for a complete list of maintenance requirements. Failure to comply with the procedures as described in the engine operator manual will nullify the warranty,

decrease performance and cause equipment damage or premature equipment failure. Maintenance records may be required to complete a warranty request.

Basic Maintenance Schedule

Item	As Required	First 50 Hours	Every 250 Hr	Every 500 Hr	Every 24 Months
Drain Water Separator	♦				
Check/Replace Air Cleaner Element	♦				
Replace Engine Oil and Filter*		♦	♦		
Inspect/Clean Solenoid Fuel Pump Filter		♦	♦		
Inspect/Adjust Belt			♦		
Check Radiator and Hose Clamps			♦		
Replace Fuel Filter				♦	
Inspect/Adjust Valve Clearance				♦	
Check/Clean Battery				♦	
Replace Engine Coolant					♦
Replace Radiator Hose Clamps					♦

*Actual oil life and change intervals should be determined through oil sampling and analysis in extreme conditions.

Features:

- Premium OEM filters
- Convenient kit vs ordering separately.
- Internal record keeping for your machine to show service was ordered, should a warranty issue ever arise.

Ordering:

- RCM-SK170 (1000hr Kit)
 - 4 Oil Filters
 - 4 Fuel Filters
 - 2 Air Filters
 - 1 Belt
- RCM-SK171 (2000hr Kit)
 - 8 Oil Filters
 - 8 Fuel Filters
 - 4 Air Filters
 - 1 Belt



www.genesislamp.com
info@genesislamp.com
Toll Free: 800-685-5267

GENESIS LAMP

375 North St. Clair St.
Painesville, OH 44077

Custom Fitted Cover for RCM-D L-893(L) Runway Closure Marker

Custom Fitted Cover for RCM-D L-893(L) Runway Closure Marker

- Durable, long lasting cover
- Easy, 1 person application



Set Up Procedure (5 minutes):



1. Fold "X" to stored position, apply cover



2. Apply front strap around vertical support bar



3. Apply side strap to RCM door latch



4. Apply (2) Back straps to Hitch mount or, if Hitch installed, around hitch bar



www.genesislamp.com
info@genesislamp.com
Toll Free: 800-685-5267

GENESIS LAMP

375 North St. Clair St.
Painesville, OH 44077

Rear Receiver Hitch for RCM-D L-893(L) Runway Closure Marker

Rear Receiver Hitch
-For towing tandem
RCM Units
-Easy 4 bolt
installation





www.genesislamp.com
info@genesislamp.com
Toll Free: 800-685-5267

RCM-Battery Backup Option

GENESIS LAMP

375 North St. Clair St.
Painesville, OH 44077



**2 Premium
Cycle on board
batteries for 24
hour operation
without
generator**



**Battery Backup
manual on/off
switch**

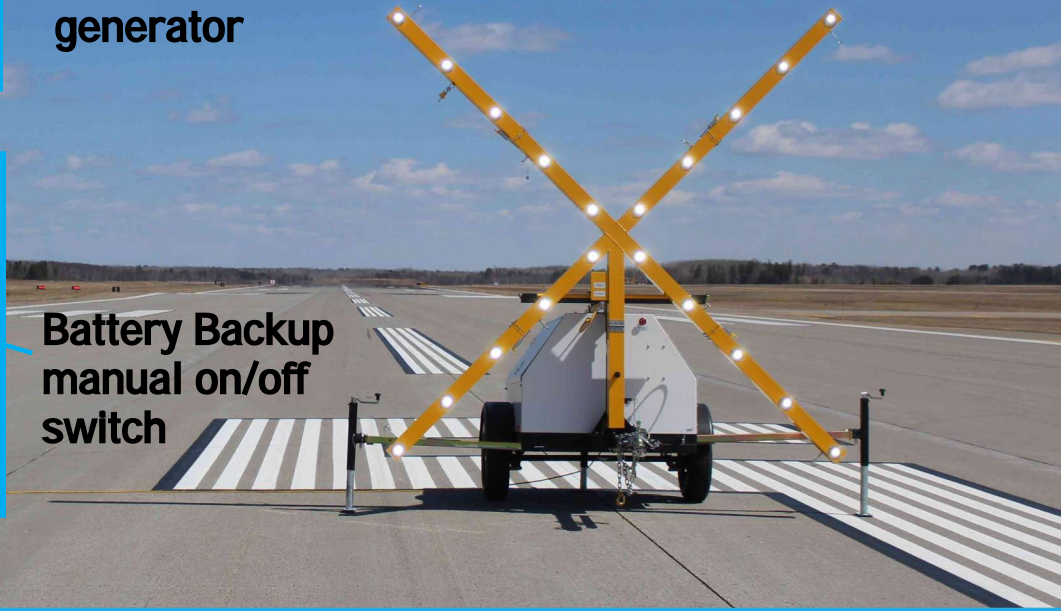

Applications:

- The Runway Closure Marker battery backup option automatically switches to battery backup when generator power is lost or turned off.
- Use for automatic battery backup for safety in the event of generator power loss
- Use for fuel savings.

(For example; run the generator during the daytime work hours, then manually turn the machine off at the end of the shift. The lighted "X" will continue to function overnight, using no fuel. When the next morning shift starts, the machine would be manually restarted and ran during the daytime shift, operating the lights and recharging the batteries, repeat)

Features:

- 2 premium deep cycle, long lasting batteries
- 24 hour operation on fully charged batteries
- Machine starting battery completely separate from battery backup system
- Automatic power sensing relay, automatically senses power loss and switches to battery
- Manual override switch conveniently located on main control panel
- High quality, on-board charger, specifically calibrated for RCM Battery backup system, resulting in longer battery life



www.genesislamp.com
info@genesislamp.com
Toll Free: 800-685-5267

GENESIS LAMP

375 North St. Clair St.
Painesville, OH 44077

RCM-ADAPTERCORD Shore Power Adapter Cord



RCM adapter cord for shore power applications. 2' cord adapts lighted "x" plug so it can be plugged directly into any standard 120v, 15 or 20amp power outlet



Applications:

- When "Shore Power" is available, the lighted "X" can be operated on any external power source from 110-250Volt, 50/60hz. This option is great for fuel and maintenance savings.

Use:

- Lighted "x" plug is 30amp 250V (NEMA L6-30P)
- RCM-ADAPTERCORD is a short cord that converts the 30amp 250V plug to a standard 120v 15amp plug.
- Simply unplug the lighted "X" from the generator control panel, Plug in the Adapter cord, then plug the 120v plug into any common outlet or extension cord. lighted "x will begin to flash

