

# Solar LED Airfield Light

A650

SOLAR LIGHTS - 7.1



Wireless



Non-wireless

## PRODUCT APPLICATION

- Taxiway and apron edge
- Construction, barricades and fences
- Temporary or permanent markings
- Helipads
- Hazard marking

## COMPLIANCES

FAA L-861T and ICAO Annex 14. The A650 Wireless Blue is compliant with the requirements of ICAO Annex 14, Volume 1, Sixth Edition (2013).

## FEATURES

- **Easy Installation and Relocation:** No specialized work crew required. Lights are immediately operational with limited air traffic disruption. The A650 can be quickly relocated for temporary or emergency applications.
- **Self-contained and Low Maintenance:** All components are incorporated within a compact, stand-alone unit. The A650 features a replaceable battery pack that extends the service life beyond five years, reducing the total cost of ownership and resulting in significant cost savings.
- **Unprecedented Reliability:** Energy Management System (EMS) monitors and adapts the brightness to environmental conditions for consistent operation and long life under the toughest conditions.
- **Designed and Tested to Tough Industrial Standards:** MIL-STD-202G Humidity, Immersion, Vibration, Shock; MIL-STD-810G: Solar Radiation, Salt Fog; EN 60945: ESD, EMI, EMC; IP68; L70. The A650 is acceptable for barricade and construction applications at Commercial Part 139 Airports under FAA Advisory Circular AC 150/5370-2E.
- **User Friendly:** Easy configuration and programming options including: on-board user interface, infrared remote and device manager software through USB connection or optional wireless control system offering secure 900 MHz.

## OPTIONS



OPTIONAL  
INFRARED  
PROGRAMMER

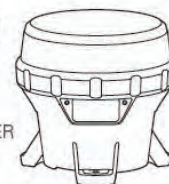

NON-WIRELESS A650



WIRELESS A650



- 4 km (2.5 m) control range
- 900 MHz with encrypted signal
- Control 8 groups of lights independently

OPTIONAL HANDHELD CONTROLLER



## SPECIFICATIONS

Solar Panel	High-efficiency cells with bypass and blocking diode function Maximum power point tracking (MPPT) for optimal energy collection.
Battery	Tool-less, replaceable and recyclable best-in-class battery pack with extreme temperature range. Battery status feedback of Good, Charge or Bad (Replace).
Light Source	High power LED. Color-specific temperature corrected LED drivers provide consistent intensity under all operating conditions.
Intensity	Greater than 10 cd intensity, steady-on (see photometric plots).
Flash Patterns	256+ (non-wireless) Steady-on mode and flash patterns (wireless).
Construction	Premium grade UV resistant, polycarbonate/polysiloxane copolymer body and lens material. Double O-ring sealing with waterproof vent.
Colors	Blue, Red, Yellow, Green and White ICAO and SAE25050 (FAA) compliant chromaticity. NVG-compatible infrared (IR) LEDs (wireless only).
Operating Temperature	-43 to 51 °C (-45 to 124 °F) ambient temperature. The A650 will function up to 190 °F (88 °C) internal and surface temperatures.
Storage Temperature	-43 to 80 °C (-45 to 176 °F).
Colour Indicator	Yes, FAA Eng. Brief 67 compliant.
Weight	1.6 kg (3.5 lb).
Wind Loading	644 km/h (400 MPH).
Automatic Light Control (ALC)	When enabled, ALC will dynamically reduce brightness in response to unusually low amounts of sunlight to ensure continued operation.
Radio Receiver	900 MHz ISM (wireless).
Range	Up to 4 km (2.5 m) (wireless).

## DIMENSIONS

Side View

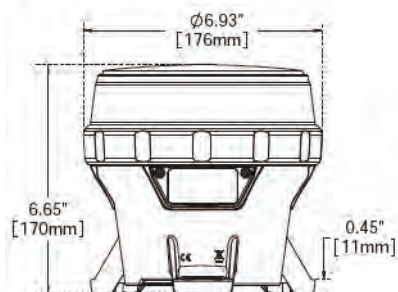

Bottom View

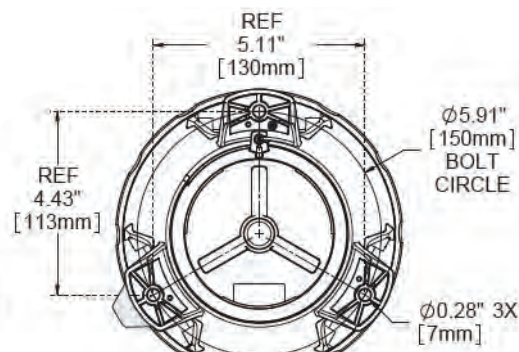

Switched View

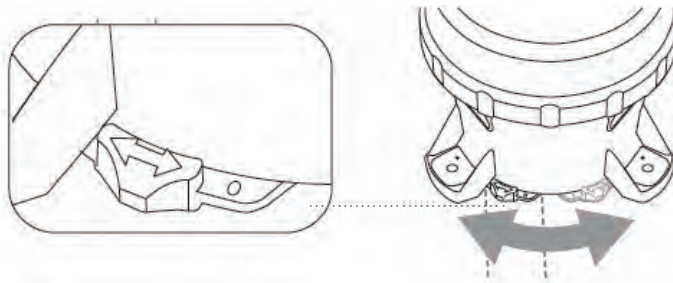

## PHOTOMETRICS

### A650 Non-Wireless

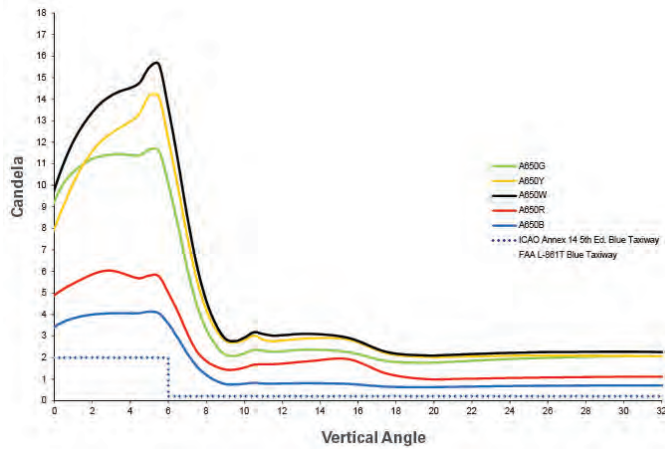

Note: Intensity dependent on location. Based on equatorial location of 12-hour night duration and steady-on (001) flash code.

### A650 Wireless

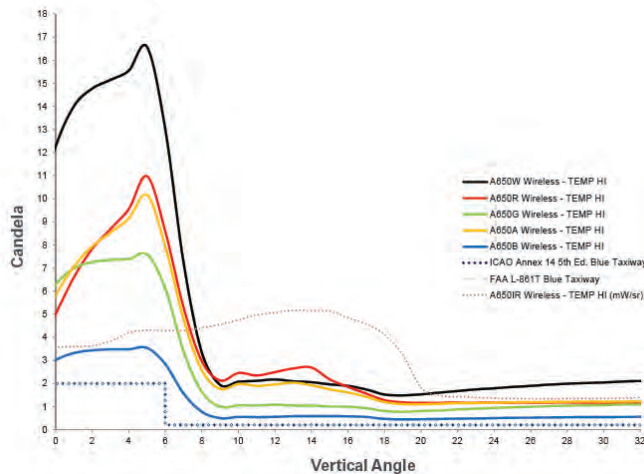

## CONFIGURATION

MODEL	OUTPUT	SWITCH	CONTROL
A650	RED GREEN WHITE YELLOW BLUE	NON-SWITCHED SWITCHED*	NON-WIRELESS WIRELESS*

\*A650 Wireless version must have switch.

## ACCESSORIES

The A650 Series taxiway and apron edge lights include several mounting options and a variety of additional accessories and replacement parts.

## MOUNTING HARDWARE

REF.	PART NO.	DESCRIPTION
1	64559*	Mat kit and hardware
2	61869*	Fence mounting kit with hardware
3A	38334*	Standard bolt kit, A650 series (3x stainless steel bolts)
3B	56578	Security bolt kit, A650 series
-	53284	Security bolt kit, driver
-	53285	Security bolt kit, socket
4A	66699*	Standard mounting plate (14" installed height)
4B	69752*	Extended mounting plate (24" installed height)
5	65711*	Frangible coupling, 1.5" pipe x 2 thread
6	50144*	Floor flange, 2" thread
7	46397*	Anchor bolt kit
8A	38925*	2" hub stake - 15" long
8B	38964*	2" hub stake - 30" long
-	61870	Stake mounting kit, soft ground
-	51925	Standard mounting plate, 1" pipe
-	50145	Frangible coupling, 1" pipe x 2" thread
-	61867*	Magnet mounting kit (3x magnets, nuts & washers)
-	61876	Magnetic sign mount

## BATTERY/CHARGER

REF.	PART NO.	DESCRIPTION
-	72835	Battery kit, A650 series
-	59188	Charger: A650, 100-240 VAC 50/60 Hz

## OPTICS

REF.	PART NO.	DESCRIPTION
-	Inquire	Optical shield, 180 degree, several models

## MISCELLANEOUS PARTS

REF.	PART NO.	DESCRIPTION
9	57003	Bird deterrent, A650 series
10	56150	Replacement antenna
11	48473	Handheld Controller
-	57392	Bottom cover replacement kit (with switch)
-	57393	Bottom cover replacement kit (without switch)
-	59198	Bottom cover access tool
-	48984	Installation tool kit with 5/32" security bit for head/battery changes and small socket set

## EXPLODED VIEW

### A650 SERIES MOUNTING HARDWARE OPTIONS

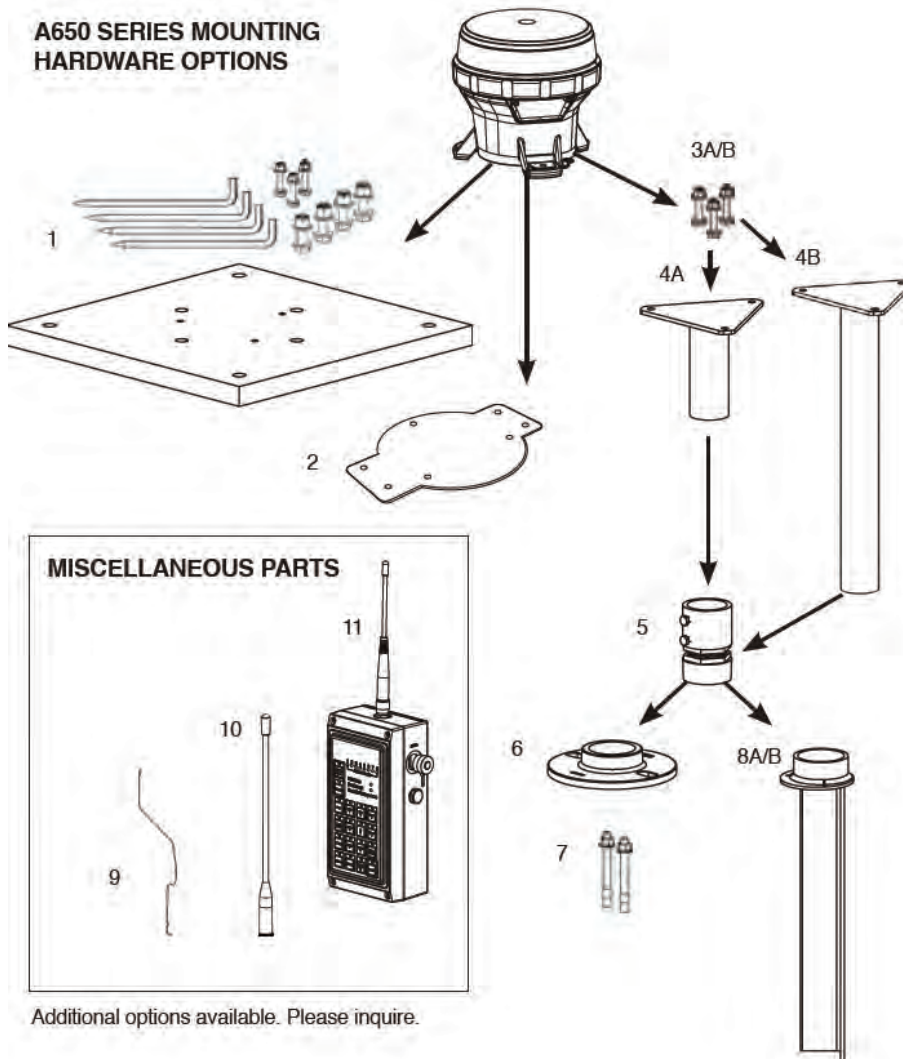

Additional options available. Please inquire.



**GENESIS LAMP**

www.genesislamp.com  
info@genesislamp.com  
Toll Free: 800-685-5267

375 North St. Clair St.  
Painesville, OH 44077